

Basic Level Education 2025

अनिवार्य गणित Compulsory Mathematics

कक्षा (Class): 8

पूर्णाङ्क (Full Marks): 50

समय (Time): 2 hours

सबै प्रश्न अनिवार्य छन्। Attempt all questions.

1) दुईओटा समूहहरू A र B लाई भेनचित्रमा प्रस्तुत गरिएको छ। Two sets A and B are presented in the Venn diagram.

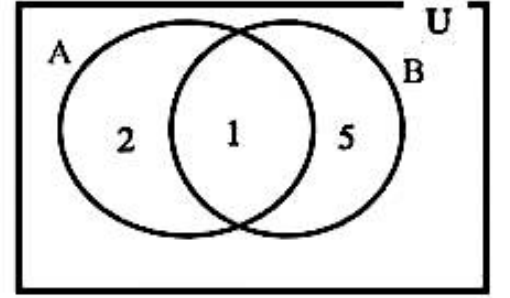

A) समूह A र समूह B अलगिएका वा खट्टिएका कस्ता समूह हुन् पहिचान गरी लेख्नुहोस्। Identify and write whether the sets A and B are overlapping or disjoint? 1 mark

B) समूह B बाट बन्ने अनुपयुक्त उपसमूह उल्लेख गर्नुहोस्। Illustrate improper subset can be made from set B. 1 mark

C) समूह A र समूह B बाट बढीमा कतिवटा साझा उपयुक्त उपसमूहहरू बनाउन सकिनेछन्? How many maximum common proper subsets can be made from set A and set B? 1 mark

2) एकजना अधिकृतको मासिक तलब रु. 43,689 छ। उनको मासिक बचत रकम भन्दा खर्च रकम दोब्बर छ। The monthly salary of an officer is Rs. 43,689. The expenditure amount is double of the saving amount in the month.

A) उनले एक वर्षमा जम्मा तलब कति पाउँछन्? How much salary does he/she get in one year? 1 mark

B) उक्त मासिक तलबमानलाई पञ्चआधार सङ्ख्या पद्धतिमा रूपान्तरण गर्नुहोस्। Convert the amount of monthly salary in the quinary number system. 2 marks

C) उनले एक महिनामा कति रकम बचत गर्छन्? How much amount did he/she save in a month? 2 marks

3) एउटा कम्प्युटरको अङ्कित मूल्य रु. 50000 छ। रामले उक्त कम्प्युटर छुटसहित रु. 42500 मा किन्यो र 10% नाफा राखी बेचेछ। The mark price of a computer is Rs. 50000. Ram bought it in Rs. 42500 after allowing discount and sold it with 10% profit.

A) अङ्कित मूल्य (MP), छुट रकम (D) र बिक्रय मूल्य (SP) भए SP लाई MP तथा D को रूपमा लेख्नुहोस्। If mark price (MP), discount amount (D) and selling price (SP) is given, write to SP in terms of MP and D. 1 mark

B) रामले उक्त कम्प्युटरमा कति रकम छुट पाएछ? पत्ता लगाउनुहोस्। How much amount did Ram get discount in a computer? Find it. 1 mark

C) रामले उक्त कम्प्युटर कतिमा बेच्यो? पत्ता लगाउनुहोस्। How much did Ram sell the computer for? Find it. 1 mark

D) उक्त कम्प्युटरको छुट रकम र नाफा रकम तुलना गर्नुहोस्। Compare the discount amount and profit amount of the computer. 1 mark

4) वि. सं. 2078 सालको जनगणनाअनुसार नेपालको जनसङ्ख्या वृद्धिदर 0.93% छ। According to the census of 2078 BS, the population growth rate of Nepal is 0.93%

A) 0.93 आनुपातिक वा अनानुपातिक कस्तो सङ्ख्या हो लेख्नुहोस्। Write 0.93 is either rational or irrational number. 1 mark

B) 0.93 लाई बैज्ञानिक सङ्केतमा रूपान्तरण गर्नुहोस्। Convert 0.93 into scientific notation. 2 marks

C) 0.93 लाई भिन्नमा रूपान्तरण गर्नुहोस्। Convert 0.93 into fraction. 2 marks

- 5) दिइएको चित्रमा समलम्ब चतुर्भुजमाथि अर्धवृत्ताकार आकृति देखाइएको छ । समलम्ब चतुर्भुजका दुई समानान्तर भुजाहरू नाप 12 से.मी. र 20 से.मी. छ भने त्यसको उचाइ 10 से.मी. छ । In the figure, a shape of semicircle is shown above the trapezium. The lengths of two parallel sides of trapezium are 12 cm and 20 cm respectively with height of 10 cm.

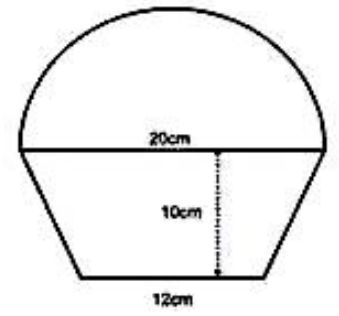

- A) समलम्ब चतुर्भुजको क्षेत्रफल पत्ता लगाउने सूत्र लेख्नुहोस् । Write the formula for finding area of trapezium. 1 mark
- B) समलम्ब चतुर्भुजको क्षेत्रफल पत्ता लगाउनुहोस् । Find the area of trapezium. 1 mark
- C) अर्धवृत्तको क्षेत्रफल भन्दा समलम्ब चतुर्भुजको क्षेत्रफल कतिले कम वा बढी छ ? गणना गर्नुहोस् । How many more or less than the area of the trapezium than the area of semicircle? Calculate it. 2 marks
- D) के समलम्ब चतुर्भुजमा एउटा विकर्ण खिच्दा बन्ने दुई त्रिभुजहरूको क्षेत्रफल बराबर हुन्छ त ? तर्कपूर्ण जवाफ दिनुहोस् । Are the areas of two triangles formed by drawing a diagonal in a trapezium equal? Give a logical answer. 1 mark
- 6) A) दुईवटा अभिव्यञ्जकहरूको ल.स. $4a^3 - 9ab^2$ र म.स. $(2a - 3b)$ छ । पहिलो अभिव्यञ्जक $(2a - 3b)$ भए दोस्रो अभिव्यञ्जक कति हुन्छ? The LCM and HCF of two expressions are $4a^3 - 9ab^2$ and $(2a - 3b)$. If the first expression is $(2a - 3b)$, what is the second expression? 2 marks
- B) सरल गर्नुहोस्: Simplify: $\frac{x^2 - 7x + 12}{x - 3} \div \frac{x - 4}{2}$ 2 marks
- 7) A) वर्ग समिकरणको एउटा उदाहरण लेख्नुहोस् । Write an example of the quadratic equation. 1 mark
- B) यदि $m = 2, n = 3, p = 1$ र $q = -2$ भए तलको अभिव्यञ्जकको मान पत्ता लगाउनुहोस् । If $m = 2, n = 3, p = 1$ and $q = -2$, find the value of the following expressions.

$$\frac{m^p \times n^q}{p^m \times q^n}$$

2 marks

- 8) तल दुईओटा समिकरण दिइएको छ । Two equations are given below.

$$x + y = 5 \text{ and } x - y = 3$$

- A) ग्राफविधि प्रयोग गरी x र y को मान पत्ता लगाउनुहोस् । Find the value of x and y by using graphical method. 2 marks
- B) माथिका समिकरणलाई कस्ता समिकरण भनिन्छ ? What equations are the above equations called? 1 mark

- 9) दिइएको चित्रमा $\triangle BDE$ समद्विबाहु त्रिभुज हो । जहाँ $AB \parallel CD$ तथा $\angle ABD = 76^\circ$ र $\angle BEF = x$ छ ।

In the adjoining figure, $\triangle BDE$ is an isosceles triangle. Where, $AB \parallel CD$,

$$\angle ABD = 76^\circ \text{ and } \angle BEF = x.$$

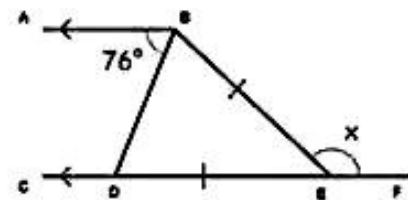

- A) कोण $\angle ABD$ सँग बराबर हुने एकान्तर कोणको नाम लेख्नुहोस् । Write the name of alternate angle equal with $\angle ABD$. 1 mark
- B) x को मान कति हुन्छ ? पत्ता लगाउनुहोस् । What is the value of x ? Find it. 2 marks

- C) फरक फरक नापका दुईओटा समद्विबाहु त्रिभुजहरू बनाई समद्विबाहु त्रिभुजका आधार कोणहरू बराबर हुन्छन् भनी प्रयोगबाट परीक्षण गर्नुहोस् ।
Experimentally verify that the base angles of an isosceles triangle are equal by making two different size of isosceles triangle. 3 marks

10) चित्रमा ΔABC र $\Delta A'B'C'$ लाई निर्देशाङ्क सतहमा देखाइएको छ । In the figure, ΔABC and $\Delta A'B'C'$ are shown in the coordinate plane.

- A) ΔABC लाई कुन अक्षमा परावर्तन गरी $\Delta A'B'C'$ बनाइएको छ ? In which axis is ΔABC reflected to form $\Delta A'B'C'$? 1 mark
B) रेखा AB को लम्बाइ गणना गर्नुहोस् । Calculate the length of line AB. 2 marks
C) के समद्विबाहु त्रिभुजबाट टेट्राहेड्रन बनाउन सकिन्छ ? कारण दिनुहोस् ।
Can a tetrahedron be made from an isosceles triangle? Give reason. 1 mark

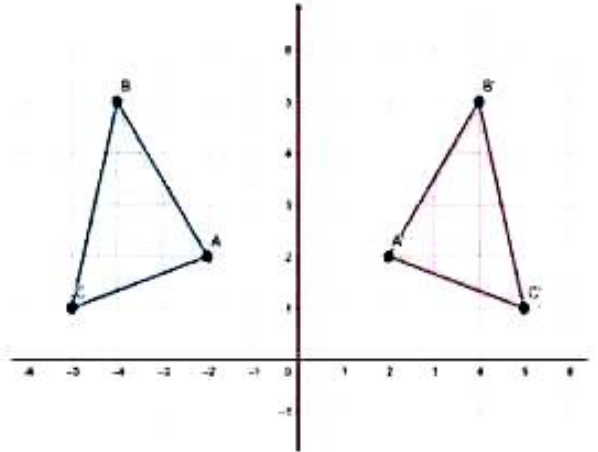

11) चित्रमा समानान्तर चतुर्भुज ABCD का विकर्णहरू AC र BD बिन्दु E मा काटिएका छन् । In the figure, diagonals AC and BD are intersected at E on the parallelogram ABCD.

- A) कम्पासको प्रयोग गरी समानान्तर चतुर्भुज ABCD को रचना गर्नुहोस् । जहाँ, $DC = 5$ cm र $BC = 4$ cm तथा $\angle ADC = 120^\circ$ छ । Construct a parallelogram ABCD by using compass, where $DC = 5$ cm, $BC = 4$ cm and $\angle ADC = 120^\circ$. 3 marks
B) प्रमाणित गर्नुहोस् । Prove that : $\Delta ABC \cong \Delta ADC$ 2 marks

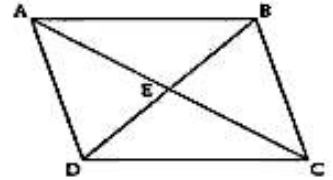

12) तल दिइएको तालिकामा एउटा परिवारको तीन महिनाको मासिक खर्चको विवरण दिइएको छ । In the table given below, the monthly expenditure of a family of three months is given.

महिना (Month)	खर्च रकम रु. मा (Amount of Expenditure in Rs.)
वैशाख (Baisakh)	24000
जेठ (Jetha)	28000
असार (Asar)	20000

- A) माथिको तथ्याङ्कलाई वृत्त चित्रमा प्रस्तुत गर्नुहोस् । Represent the above information in the pie-chart. 2 marks
B) माथि दिइएको तथ्याङ्कबाट तीन महिनाको औसत खर्च गणना गर्नुहोस् । Calculate the average expenditure of three months of the above data. 1 mark

-The End-

Marking Scheme of the model set-1

- 1) A) Sets A and B are overlapping sets 1 mark
- B) $\{1, 5\}$ 1 mark
- C) 2 common proper subsets made from set A and B. i.e. $\phi, \{1\}$ 1 mark
- 2) A) Yearly Salary = Rs. 524268
- OR, Yearly Salary = $12 \times 43689 = \text{Rs. } 524268$ 1 mark
- B) Dividing by 5 as follows: 1 mark
- $43689 / 5 = 8737$ with remainder 4
 $8737 / 5 = 1747$ with remainder 2
 $1747 / 5 = 349$ with remainder 2
 $349 / 5 = 69$ with remainder 4
 $69 / 5 = 13$ with remainder 4
 $13 / 5 = 2$ with remainder 3
 $2 / 5 = 0$ with remainder 2
- Thus, $436895 = 2344224_5$ 1 mark
- C) $x + 2x = 43689$ 1 mark
- Saving amount in a month = Rs. 14563 1 mark
- 3) A) $SP = MP - D$ 1 mark
- B) Discount amount = Rs. 7500
- OR, Discount amount = $MP - CP = 50000 - 42500 = \text{Rs. } 7500$
- OR, Discount amount = $50000 - 42500 = \text{Rs. } 7500$ 1 mark
- C) $SP = \text{Rs. } 46750$
- OR, $SP = CP + 10\% \text{ of } CP = 42500 + 4250 = \text{Rs. } 46750$
- OR, $SP = 42500 \times 1.1 = \text{Rs. } 46750$ 1 mark

D) Required Ratio = 30:17 or 17:30

OR, Discount amount is Rs. 3250 more than profit amount

OR, Profit amount is Rs. 3250 less than discount amount 1 mark

4) A) 0.93 is a rational number 1 mark

B) $0.93 = \frac{93}{100}$ 1 mark

$0.93 = 9.3 \times 10^{-1}$ 1 mark

C) Let $x = 0.9393$ and $100x = 93.9393$ 1 mark

$0.\overline{93} = \frac{31}{33}$ 1 mark

5) A) Area of trapezium = $\frac{1}{2}(a + b) \times h$ sq. unit 1 mark

B) $A = \frac{1}{2}(12 + 20) \times 10 = 160 \text{ cm}^2$

OR, $A = 160 \text{ cm}^2$ 1 mark

C) Area of semicircle = 157.14 cm^2

OR, Area of semicircle = $\frac{\pi r^2}{2} = \frac{22 \times 10 \times 10}{7 \times 2} = 157.14 \text{ cm}^2$ 1 mark

Area of trapezium is 2.86 cm^2 more than area of semicircle 1 mark

D) Yes, both have equal areas. 1 mark

6) A) $(4a^3 - 9ab^2)(2a - 3b) = (2a - 3b) \times 2^{\text{nd}} \text{ exp}$ 1 mark

$2^{\text{nd}} \text{ exp} = (4a^3 - 9ab^2)$ 1 mark

B) $\frac{x^2 - 7x + 12}{x - 3} \div \frac{x - 4}{2} = \frac{(x - 3)(x - 4)}{x - 3} \times \frac{2}{x - 4}$ 1 mark

$= 2$ 1 mark

7) A) Any one example (eg. $x^2 + 5x + 6 = 0, x \neq 0$) 1 mark

B) $\frac{m^p \times n^q}{p^m \times q^n} = \frac{2^1 \times 3^{-2}}{1^2 \times (-2)^3}$
 $= \frac{1}{36}$

1 mark

1 mark

8) A) for correct graphical representation

$x = 4$ and $y = 1$

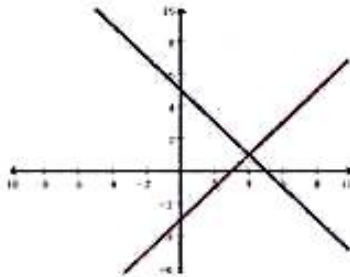

1 mark

1 mark

B) Simultaneous equations

1 mark

9) A) $\angle ABD = \angle BDE$

1 mark

B) $\angle BED = 28^\circ$

1 mark

$x = 152^\circ$

1 mark

C) Two different shaped figures with naming

1 mark

Correct tabulation

1 mark

Obtained data by used protractor.

1 mark

10) A) Reflection on y - axis

1 mark

B) $A = (-2,2)$, $B = (-4,5)$

1 mark

$AB = \sqrt{13}$ unit

1 mark

C) Nets of tetrahedron (anyone)

1 mark

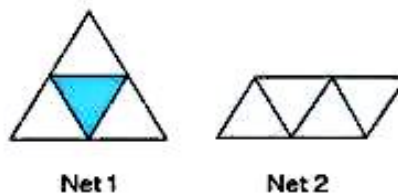

Net 1

Net 2

11) A) Draw line $DC = 5$ cm and $\angle ADC = 120^\circ$

1 mark

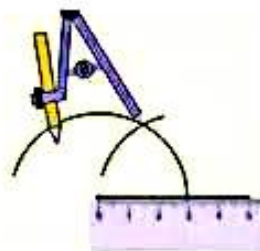

$DA = BC = 4 \text{ cm}$

1 mark

ABCD is a parallelogram

B) $AB = DC$ (S), $\angle B = \angle D$ (A), $AC =$
1 mark

$\triangle ABC \cong \triangle ADC$ by SAS

1 mark

12) A) Central Angles $120^\circ, 140^\circ, 100^\circ$

B) Correct pie chart (Expenditure in
three months)

C) Average expenditure = Rs. 24000

OR, $\frac{24000+28000+20000}{3} = \text{Rs. } 24000$

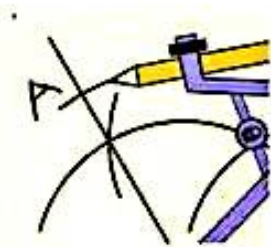

1 mark

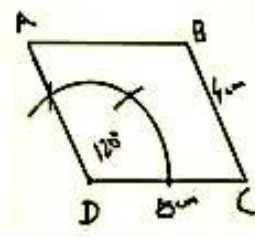

AC(S)

1 mark

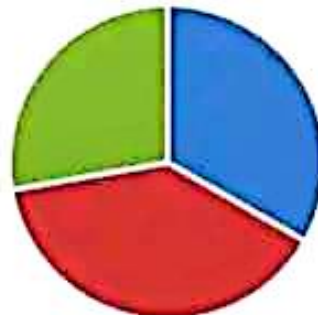

1 mark

■ Baisakh ■ Jestha ■ Ashar ■

1 mark

Test matrix of the model set

S N	Areas	Question no.	Cognitive Level				In the set		Required	
			K (16%)	U (24%)	A (40%)	HA (20%)	Total Marks	No. of Items	Total Marks	No. of Question (Items)
1	Set	1	1		1	1	3	3	3	2(5)
2	Statistics	12		1	2		3	2	3	
3	Arithmetic	2		1	2 + 2		5	3	14	3(10)
		3	1	1	1	1	4	4		
		4	1	2		2	5	3		
4	Mensuration	5	1	1	2	1	5	4	5	1(4)
5	Algebra	6			2	2	4	2	10	3(6)
		7	1	2			3	2		
		8	1		2		3	2		
6	Geometry	9	1	2	3		6	3	15	3(8)
		10	1	2		1	4	3		
		11			3	2	5	2		
Total			8	12	20	10	50	33	50	12(33)

Contributors: NEB Item Development Training Participants, Dang 2081, Mansir